

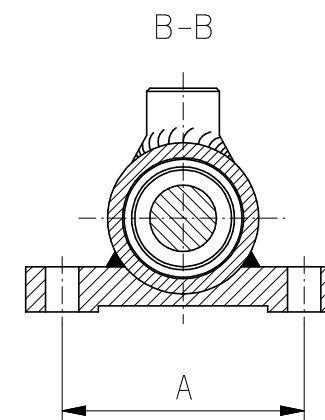

Uwagi:

- Ciśnienie pracy 21 MPa
- Ciśnienie próbne 25 MPa
- Temperatura pracy -25°C do 120°C
- Ciśnienie max. 30 MPa
- Zakres d (50-185)
- Zakres skoku (90-1500)
- Zakres L_{min} (380 \geq)



	Nazwa rys. :	Ofertowy
	Nr rys. wewn.:	SHD6-D/dxH
STALKO sp. z o.o. sp. k. WROCLAW ul. Nowodworska 19		